

## CRJ1000



### Compartments:

#### Maximum weights and volumes:

#### Forward Compartment 4 and 5

Note: All measurements in cm.

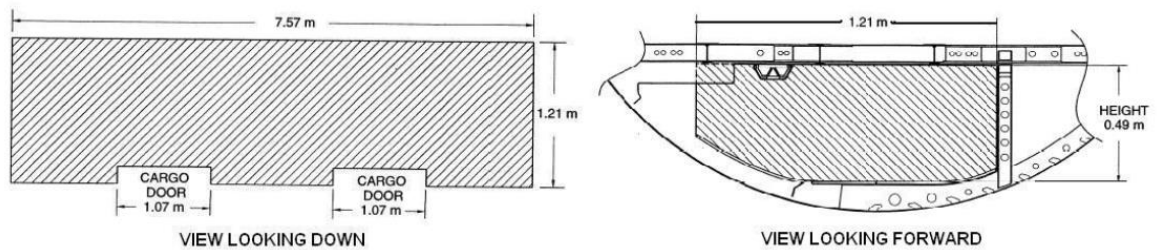

CM	HEIGHT				
	7.6	15.2	20.3	25.4	30.5
WIDTH	MAXIMUM LENGTH				
7.6	381.0	304.8	254.0	228.6	190.5
15.2	304.8	254.0	228.6	203.2	177.8
20.3	279.4	241.3	215.9	190.5	177.8
30.5	228.6	215.9	190.5	177.8	165.1
38.1	203.2	177.8	165.1	157.4	152.4
45.7	177.8	152.4	139.7	127.0	116.8
55.8	45.7	45.7	45.7	45.7	45.7
63.5	45.7	45.7	45.7	45.7	45.7
76.2	45.7	45.7	45.7	45.7	45.7
91.4	45.7	45.7	45.7	45.7	45.7
101.6	45.7	45.7	45.7	N/A	N/A
Maximum Package Dimension					

Aft Compartment 6

Note: All measurements in cm.

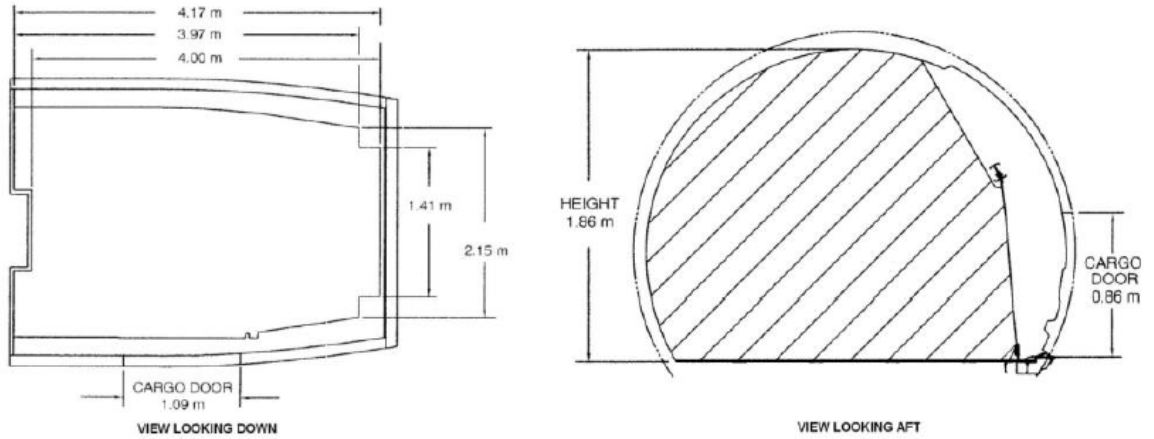

CM	HEIGHT													
	7.6	15.2	20.3	25.4	30.5	35.6	40.6	45.7	48.3	53.3	63.5	73.6	81.3	
WIDTH	MAXIMUM LENGTH													
7.6	279.4	279.4	279.4	279.4	279.4	279.4	279.4	279.4	279.4	279.4	279.4	279.4	279.4	279.4
15.2	266.7	266.7	266.7	266.7	266.7	266.7	266.7	266.7	266.7	266.7	266.7	266.7	266.7	266.7
20.3	266.7	266.7	266.7	266.7	266.7	266.7	266.7	266.7	266.7	266.7	266.7	266.7	266.7	266.7
30.5	254.0	254.0	254.0	254.0	254.0	254.0	254.0	254.0	254.0	254.0	254.0	254.0	254.0	254.0
38.1	254.0	254.0	254.0	254.0	254.0	254.0	254.0	254.0	254.0	254.0	254.0	254.0	254.0	254.0
45.7	254.0	254.0	254.0	254.0	254.0	254.0	254.0	254.0	254.0	254.0	254.0	254.0	254.0	254.0
50.8	241.3	241.3	241.3	241.3	241.3	241.3	241.3	241.3	241.3	241.3	241.3	241.3	241.3	241.3
55.9	228.6	228.6	228.6	228.6	228.6	228.6	228.6	228.6	228.6	228.6	228.6	228.6	228.6	228.6
63.5	228.6	228.6	228.6	228.6	228.6	228.6	228.6	228.6	228.6	228.6	228.6	228.6	228.6	228.6
76.2	228.6	228.6	228.6	228.6	228.6	228.6	228.6	228.6	228.6	228.6	228.6	228.6	228.6	228.6
83.8	228.6	228.6	228.6	228.6	228.6	228.6	228.6	228.6	228.6	228.6	228.6	228.6	228.6	228.6
88.9	215.9	215.9	215.9	215.9	215.9	215.9	215.9	215.9	215.9	215.9	215.9	215.9	215.9	215.9
101.6	203.2	203.2	203.2	203.2	203.2	203.2	203.2	203.2	203.2	203.2	203.2	203.2	203.2	N/A
Maximum Package Dimension														

Below is valid for compartment 6.

Caution 1: Take extra care when loading compartment 6 as the cargo door is right below the LH engine. This limits the size of the items possible to load without risking damage to the LH engine cowling.

Caution 2: Due to the critical position of the compartment, relative to the engine cowling, it is prohibited to place the conveyor belt inside the compartment. During loading, the upper side of the conveyor belt shall never be higher than 10 cm above the compartment floor.

Caution 3: If the cargo item is higher than 60 cm, the use of a belt loader is prohibited to prevent damage to the LH engine cowling. Max height loadable in CPT6, is 60 cm.

Air conditioning system:

This table shows the ventilation and heating/cooling possibilities in each compartment.

Topic	Forward	Compartment 6
Temperature	Above 2°C at any time (depends on the initial temperature in the compartment)	16°C - 27°C
Heat	No	Yes
Heat adjust (see Note below)	No	Yes (see Note below)
Cooling	No	Yes
Ventilation	No	Yes
Pressurization	Yes	Yes

**Note:** If the temperature is +27°C or below, it is not possible to further reduce the temperature with the aircraft's air conditioning system.

**Restrictions:**

Dangerous Goods

Dry Ice: Maximum amount in Compartment.

		Maximum amount of ICE per compartment Combined weight	
A/C version	Maximum amount of ICE per A/C	Forward	Aft
CRJ1000	100 kg	0 kg	100 kg

**Note:** Not to be loaded in the same hold as Live Animals (AVI).

Radioactive Materials: Maximum Transport Index (TI)

			Max TI pr. Compartment	
A/C version	Max TI pr. aircraft	Max TI pr. package (or Group of packages)	1	6
CRJ1000	3	3	N/A	3

Radioactive Materials: Maximum Package/Group Height and Separation Distance

Maximum Package height and separation distance is not relevant as **RRW/RRY can only be loaded in Compartment 6.**

Heavy

The maximum weight per item is 80 kg. Items weighing 81 kg or more shall not be loaded on the CRJ1000 aircraft.

### Human Remains

Human remains (coffins and other containers) may be carried taking into account segregation with other cargo, maximum package dimensions, cargo door dimensions and access to cargo compartment.

The maximum weight per item is 80 kg. Items weighing 81 kg or more shall not be loaded on the CRJ1000 aircraft.

HUM may be loaded in the same hold as AVI, EAT and LHO, but shall not be loaded in close proximity of these. If possible, use different holds/compartments for the items mentioned above.

### Live Animals

**Embargo for animals shipped as cargo.** This embargo **does not** apply to tropical fish/fish and crustaceans, as they do not need oxygen during transport.

Cats, dogs, birds and other mammals are permitted as baggage on CRJ1000. Based on the size of the compartments and the expected space needed for bags, cargo and mail on this AC type, embargo for animals shipped as cargo is imposed.

### Live Human Organs

Live Human Organs (LHO) shall be loaded in compartment 6, as close as possible to the door section.

### Perishables

No aircraft restrictions other than maximum dimensions, area load and maximum load in hold, but always check SIRIUS for current restrictions on origin, destination and possible embargoes.

### Sensitive

Load, which is sensitive to shock and tilting (e.g. musical instruments in soft cases) shall not be loaded in the compartments of CRJ. This is due to the risk of damage during loading, stowing and unloading.

### Valuable

No aircraft restrictions other than maximum dimensions, area load and maximum load in hold, but always check SIRIUS for current restrictions on origin, destination and possible embargoes.

Vulnerable

No aircraft restrictions other than maximum dimensions, area load and maximum load in hold, but always check SIRIUS for current restrictions on origin, destination and possible embargoes.

**Document info:**

<b>Author:</b>	<b>Approved by:</b>	<b>Effective date:</b>
Michael Beck Damkjær, CPHFD	Michael Beck Damkjær, CPHFD	01FEB2018
<b>Document review date:</b>	<b>Document review by:</b>	<b>Department:</b>
01FEB2018	Michael Beck Damkjær, CPHFD	CPHFD
<b>SCM Document:</b>	<b>SAS Cargo Document:</b>	<b>Live Document:</b>
Yes	Yes	Yes